

## TFT LCD Preliminary Specification

**MODEL NO.: M185B3-L01**

Customer:	_____
Approved by:	_____
Note:	

**- CONTENTS -**

REVISION HISTORY ..... 3

1. GENERAL DESCRIPTION ..... 4

    1.1 OVERVIEW

    1.2 FEATURES

    1.3 APPLICATION

    1.4 GENERAL SPECIFICATIONS

    1.5 MECHANICAL SPECIFICATIONS

2. ABSOLUTE MAXIMUM RATINGS ..... 5

    2.1 ABSOLUTE RATINGS OF ENVIRONMENT

    2.2 ELECTRICAL ABSOLUTE RATINGS

        2.2.1 TFT LCD MODULE

        2.2.2 BACKLIGHT UNIT

3. ELECTRICAL CHARACTERISTICS ..... 7

    3.1 TFT LCD MODULE

    3.2 Vcc Power Dip Condition:

    3.3 BACKLIGHT UNIT

    3.4 LIGHTBAR Connector Pin Assignment

4. BLOCK DIAGRAM ..... 10

    4.1 TFT LCD MODULE

5. INPUT TERMINAL PIN ASSIGNMENT ..... 11

    5.1 TFT LCD MODULE

    5.2 LVDS DATA MAPPING TABLE

    5.3 COLOR DATA INPUT ASSIGNMENT

6. INTERFACE TIMING ..... 13

    6.1 INPUT SIGNAL TIMING SPECIFICATIONS

    6.2 POWER ON/OFF SEQUENCE

7. OPTICAL CHARACTERISTICS ..... 15

    7.1 TEST CONDITIONS

    7.2 OPTICAL SPECIFICATIONS

8. PACKAGING ..... 18

    8.1 PACKING SPECIFICATIONS

    8.2 PACKING METHOD

9. DEFINITION OF LABELS ..... 20

    9.1 CMO MODULE LABEL

10. RELIABILITY TEST ..... 21

11. PRECAUTIONS ..... 22

    11.1 ASSEMBLY AND HANDLING PRECAUTIONS

    11.2 SAFETY PRECAUTIONS

    11.3 SAFETY STANDARDS

    11.4 STORAGE

    11.5 OPERATION CONDITION GUIDE

    11.6 OTHER

12. MECHANICAL CHARACTERISTICS ..... 23

**REVISION HISTORY**

Version	Date	Section	Description
Ver 1.0	Jun,15, 09'		M185B3-L01 Preliminary specification was first issued.

## 1. GENERAL DESCRIPTION

### 1.1 OVERVIEW

M185B3-L01 is a 18.5" TFT Liquid Crystal Display module with WLED Backlight unit and 30pin 1ch-LVDS interface. This module supports 1366 x 768 WXGA mode and can display up to 16.7M colors. The inverter module for Backlight is not built in.

### 1.2 FEATURES

- Contrast ratio 1000:1
- Response time 5ms.
- Brightness 250nits
- Color saturation NTSC 68%.
- WXGA (1366 x 768 pixels) resolution.
- DE (Data Enable) only mode.
- LVDS (Low Voltage Differential Signaling) interface.
- RoHS compliance.

### 1.3 APPLICATION

- TFT LCD Monitor

### 1.4 GENERAL SPECIFICATIONS

Item	Specification	Unit	Note
Active Area	409.8 (H) × 230.4(V) (18.5" diagonal)	mm	(1)
Bezel Opening Area	413.4(H) x 234 (V)	mm	
Driver Element	a-Si TFT active matrix	-	-
Pixel Number	1366 x R.G.B. x 768	pixel	-
Pixel Pitch	0.3 (H) x 0.3 (V)	mm	-
Pixel Arrangement	RGB vertical stripe	-	-
Display Colors	16.7M	color	-
Transmissive Mode	Normally White	-	-
Surface Treatment	AG type, 3H hard coating, Haze 25	-	-
Module Power Consumption	13.2	Watt	(2)

### 1.5 MECHANICAL SPECIFICATIONS

Item	Min.	Typ.	Max.	Unit	Note	
Module Size	Horizontal(H)	429.87	430.37	430.87	mm	(1)
	Vertical(V)	254.1	254.6	255.1	mm	
	Depth(D)	-	7.85	8.35	mm	
Weight	-	1200	1250	g	-	

Note (1) Please refer to the attached drawings for more information of front and back outline dimensions.

Note (2) Please refer to sec. 3.1 & 3.2 in this document for more information of power consumption.

## 2. ABSOLUTE MAXIMUM RATINGS

### 2.1 ABSOLUTE RATINGS OF ENVIRONMENT

Item	Symbol	Value		Unit	Note
		Min.	Max.		
Storage Temperature	T <sub>ST</sub>	-20	60	°C	(1)
Operating Ambient Temperature	T <sub>OP</sub>	0	50	°C	(1), (2)
Shock (Non-Operating)	S <sub>NOP</sub>	-	50	G	(3), (5)
Vibration (Non-Operating)	V <sub>NOP</sub>	-	1.5	G	(4), (5)
LCD Cell Life Time	L <sub>CELL</sub>	50,000	-	Hrs	MTBF based
Altitude test {operating 16,400 feet(5,000m)}	AOP	-	5000	M	24hrs
Altitude test {storage 40,000 feet(12,000m)}	ANOP	-	12000	M	24hrs

Note (1) Temperature and relative humidity range is shown in the figure below.

- (a) 90 %RH Max. ( $T_a \leq 40 \text{ }^\circ\text{C}$ ).
- (b) Wet-bulb temperature should be 39 °C Max. ( $T_a > 40 \text{ }^\circ\text{C}$ ).
- (c) No condensation.

Note (2) The temperature of panel display surface area should be 0 °C Min. and 60 °C Max.

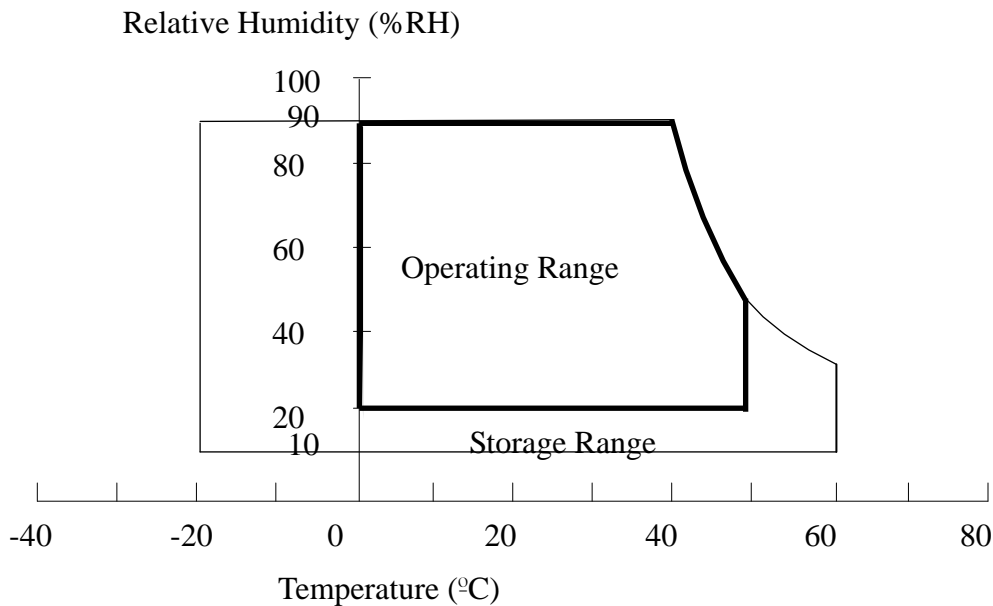

Note (3) 50G, 11ms, half sine wave, 1 time for  $\pm X$ ,  $\pm Y$ ,  $\pm Z$ .

Note (4) 10 ~ 300 Hz, 10min/cycle, 3 cycles each X, Y, Z.

Note (5) At testing Vibration and Shock, the fixture in holding the module has to be hard and rigid enough so that the module would not be twisted or bent by the fixture.

The fixing condition is shown as below:

At Room Temperature

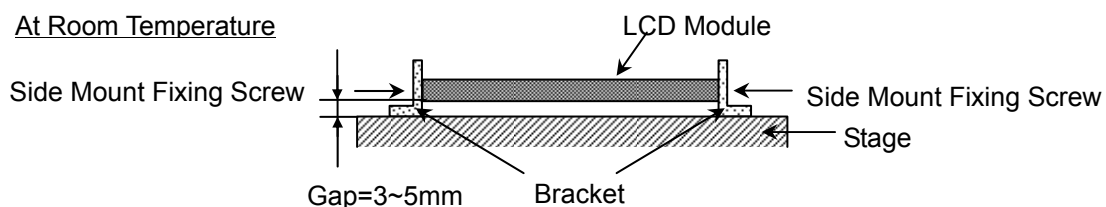

## 2.2 ELECTRICAL ABSOLUTE RATINGS

### 2.2.1 TFT LCD MODULE

Item	Symbol	Value		Unit	Note
		Min.	Max.		
Power Supply Voltage	Vcc	-0.3	+6.0	V	(1)
Logic Input Voltage	Vlogic	-0.3	2.7	V	

### 2.2.2 BACKLIGHT UNIT

Item	Symbol	Value			Unit	Note
		Min.	Typ.	Max.		
LED DC forward current	I <sub>f</sub>	---	20	30	mA	(1)
LED Peak pulse current	I <sub>p</sub>	---	---	TBD		
LED Reverse voltage	V <sub>r</sub>	---	---	39.6	V	

Note (1) Permanent damage to the device may occur if maximum values are exceeded. Function operation should be restricted to the conditions described under Normal Operating Conditions.

### 3. ELECTRICAL CHARACTERISTICS

#### 3.1 TFT LCD MODULE

Ta = 25 ± 2 °C

Parameter	Symbol	Value			Unit	Note
		Min.	Typ.	Max.		
Power Supply Voltage	Vcc	4.5	5.0	5.5	V	-
Ripple Voltage	V <sub>RP</sub>	-	-	100	mV	-
Power on Rush Current	I <sub>RUSH</sub>	-	-	3	A	(2)
Power Supply Current	White	-	0.44	0.6	A	(3)a
	Black	-	0.59	0.9	A	(3)b
	Vertical Stripe	-	0.61	0.9	A	(3)c
Power Consumption(without Backlight Unit)	PLCD	-	3.05	4.5	Watt	(4)
LVDS differential input voltage	V <sub>id</sub>	100	-	600	mV	
LVDS common input voltage	V <sub>ic</sub>	-	1.2	-	V	
Logic High Input Voltage	V <sub>IH</sub>	2.0	-	2.7	V	
Logic Low Input Voltage	V <sub>IL</sub>	-	-	0.5	V	

Note (1) The module should be always operated within above ranges.

Note (2) Power on rush current Measurement Conditions:

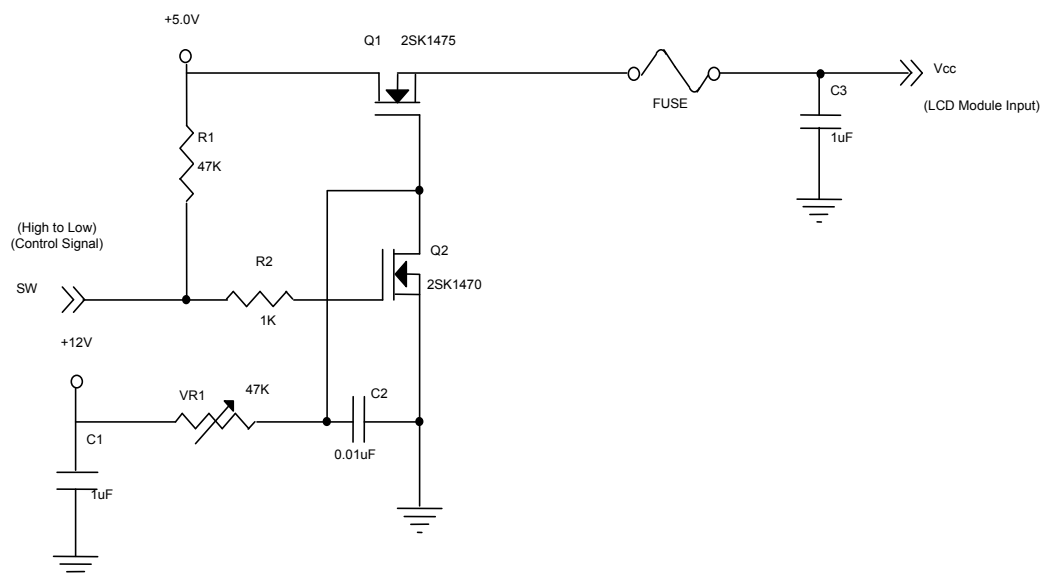

**Vcc rising time is 470μs**

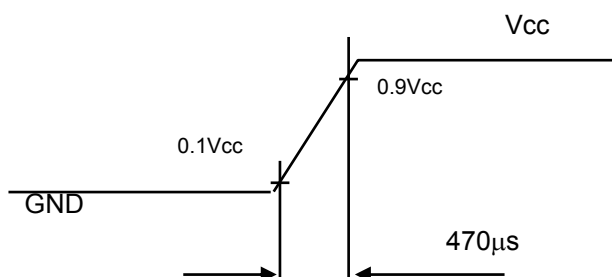

Note (3) The specified power supply current is under the conditions at  $V_{cc} = 5.0\text{ V}$ ,  $T_a = 25 \pm 2\text{ }^\circ\text{C}$ ,  $f_v = 60\text{ Hz}$ , whereas a power dissipation check pattern below is displayed.

a. White Pattern



Active Area

b. Black Pattern



Active Area

c. Vertical Stripe Pattern

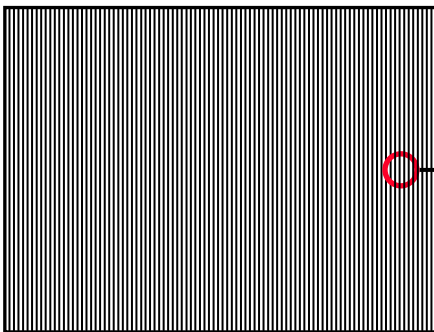

Active Area

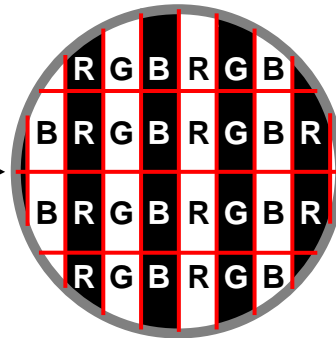

Note (4) The power consumption is specified at the pattern with the maximum current.

### 3.2 Vcc Power Dip Condition:

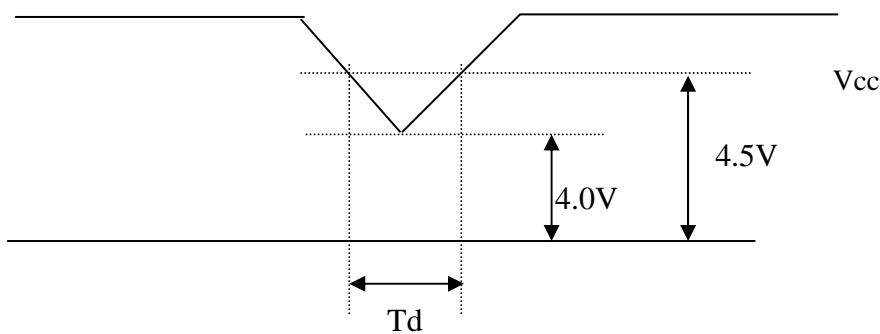

Dip condition:  $4.0\text{V} \leq V_{cc} \leq 4.5\text{V}$ ,  $T_d \leq 20\text{ms}$



### 3.3 BACKLIGHT UNIT (LED matrix is 11S14P)

Ta = 25 ± 2 °C

Parameter	Symbol	Value			Unit	Note
		Min.	Typ.	Max.		
Light Bar Input Voltage	V <sub>LED</sub>	30.8	36.3	39.6	V <sub>DC</sub>	(Duty 100%)
Light Bar Input Current	I <sub>LED</sub>	19.4	20	20.6	mA <sub>DC</sub>	(Duty 100%) per string
Power Consumption	P <sub>LED</sub>	---	10.164	---	W	(1)
LED Life Time	L <sub>BL</sub>	25000	---	---	Hrs	(2)

Note (1) P<sub>LED</sub> = (I<sub>LED</sub> × 14 ) × V<sub>LED</sub> , LED matrix is 11S14P.

Note (2) The lifetime of LED is defined as the time when it continues to operate under the conditions at Ta = 25 ±2 °C and I = 20 mA(Per EA) until the brightness becomes ≤ 50% of its original value.

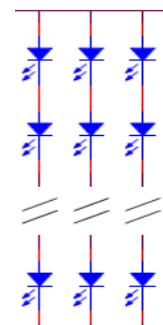
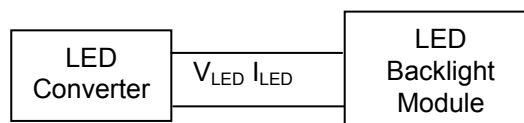

### 3.4 LIGHTBAR Connector Pin Assignment

Connector: 91500-01201-H01 (Aces)

LED: PT03A1XX SMD Top view 3528 (CMLT)

CN1

Pin number	Description
Pin1	VLED
Pin2	VLED
Pin3	NC
Pin4	Channel 1 (11 LEDs Series)
Pin5	Channel 2 (11 LEDs Series)
Pin6	NC
Pin7	Channel 3 (11 LEDs Series)
Pin8	Channel 4 (11 LEDs Series)
Pin9	NC
Pin10	Channel 5 (11 LEDs Series)
Pin11	Channel 6 (11 LEDs Series)
Pin12	Channel 7 (11 LEDs Series)

CN2

Pin number	Description
Pin1	VLED
Pin2	VLED
Pin3	NC
Pin4	Channel 8 (11 LEDs Series)
Pin5	Channel 9 (11 LEDs Series)
Pin6	NC
Pin7	Channel 10 (11 LEDs Series)
Pin8	Channel 11 (11 LEDs Series)
Pin9	NC
Pin10	Channel 12 (11 LEDs Series)
Pin11	Channel 13 (11 LEDs Series)
Pin12	Channel 14 (11 LEDs Series)

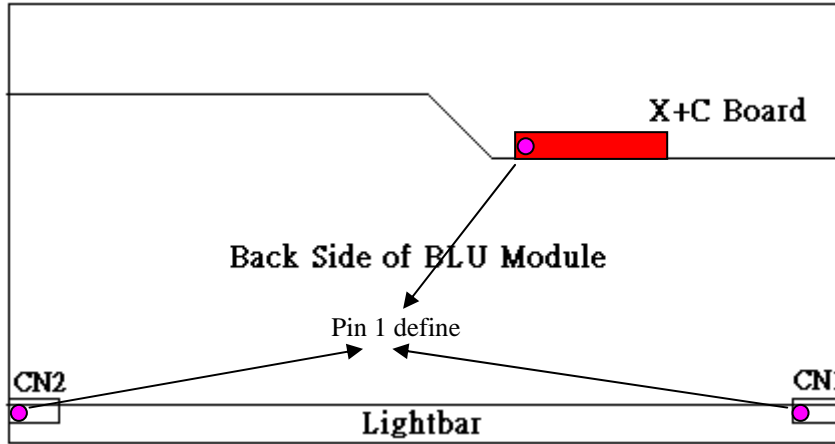

#### 4. BLOCK DIAGRAM

##### 4.1 TFT LCD MODULE

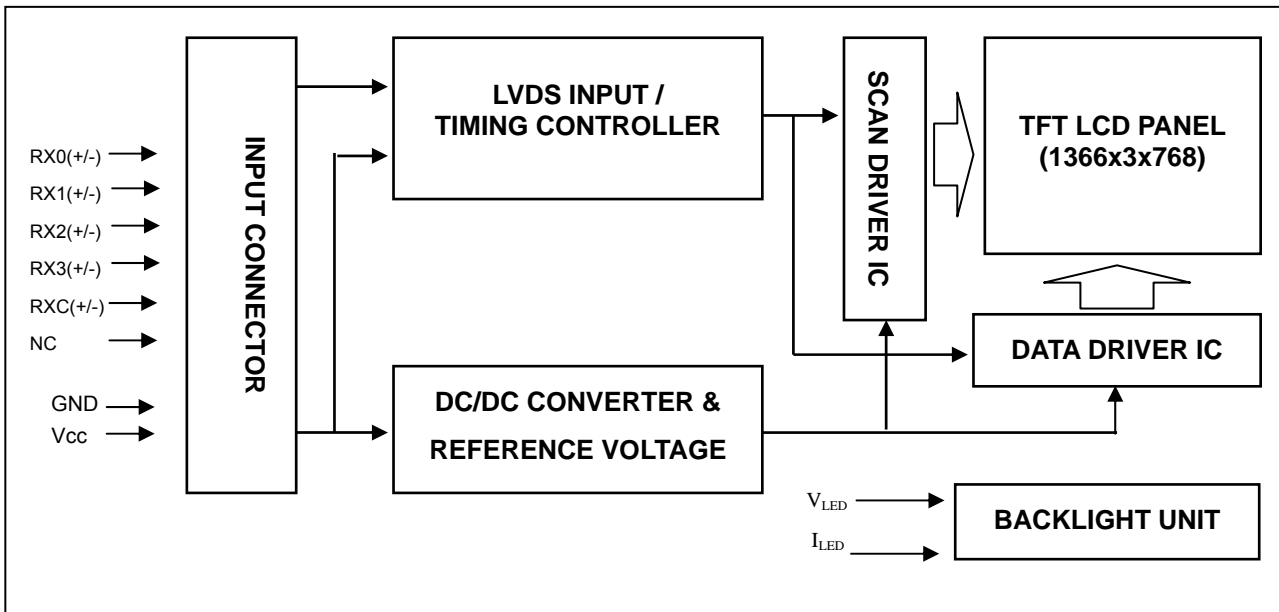

## 5. INPUT TERMINAL PIN ASSIGNMENT

### 5.1 TFT LCD MODULE

Pin	Name	Description
1	NC	Not connection, this pin should be open.
2	NC	Not connection, this pin should be open.
3	NC	Not connection, this pin should be open.
4	GND	Ground
5	RX0-	Negative LVDS differential data input. Channel 0
6	RX0+	Positive LVDS differential data input. Channel 0
7	GND	Ground
8	RX1-	Negative LVDS differential data input. Channel 1
9	RX1+	Positive LVDS differential data input. Channel 1
10	GND	Ground
11	RX2-	Negative LVDS differential data input. Channel 2
12	RX2+	Positive LVDS differential data input. Channel 2
13	GND	Ground
14	RXCLK-	Negative LVDS differential clock input.
15	RXCLK+	Positive LVDS differential clock input.
16	GND	Ground
17	RX3-	Negative LVDS differential data input. Channel 3
18	RX3+	Positive LVDS differential data input. Channel 3
19	GND	Ground
20	NC	Not connection, this pin should be open.
21	NC	Not connection, this pin should be open.
22	NC	Not connection, this pin should be open.
23	GND	Ground
24	GND	Ground
25	GND	Ground
26	Vcc	+5.0V power supply
27	Vcc	+5.0V power supply
28	Vcc	+5.0V power supply
29	Vcc	+5.0V power supply
30	Vcc	+5.0V power supply

Note (1) Connector Part No.: **STARCONN 093G30-B2001A** or equivalent

Note (2) Mating Wire Cable Connector Part No.: FI-X30H(JAE) or FI-X30HL(JAE)

Note (3) Mating FFC Cable Connector Part No.: 217007-013001 (P-TWO) or JF05X030-1 (JAE)

Note (4) The first pixel is odd.

Note (5) Input signal of even and odd clock should be the same timing.

### 5.2 LVDS mapping table

		D7	D6	D4	D3	D2	D1	D0
LVDS Channel 0	LVDS output	D7	D6	D4	D3	D2	D1	D0
	Data order	G0	R5	R4	R3	R2	R1	R0
LVDS Channel 1	LVDS output	D18	D15	D14	D13	D12	D9	D8
	Data order	B1	B0	G5	G4	G3	G2	G1
LVDS Channel 2	LVDS output	D26	D25	D24	D22	D21	D20	D19
	Data order	DE	NA	NA	B5	B4	B3	B2
LVDS Channel 3	LVDS output	D23	D17	D16	D11	D10	D5	D27
	Data order	NA	B7	B6	G7	G6	R7	R6

### 5.3 COLOR DATA INPUT ASSIGNMENT

The brightness of each primary color (red, green and blue) is based on the 8-bit gray scale data input for the color. The higher the binary input, the brighter the color. The table below provides the assignment of color versus data input.

Color		Data Signal																							
		Red								Green								Blue							
		R7	R6	R5	R4	R3	R2	R1	R0	G7	G6	G5	G4	G3	G2	G1	G0	B7	B6	B5	B4	B3	B2	B1	B0
Basic Colors	Black	0	0	0	0	0	0	0	0	0	0	0	0	0	0	0	0	0	0	0	0	0	0	0	0
	Red	1	1	1	1	1	1	1	1	0	0	0	0	0	0	0	0	0	0	0	0	0	0	0	0
	Green	0	0	0	0	0	0	0	0	1	1	1	1	1	1	1	1	0	0	0	0	0	0	0	0
	Blue	0	0	0	0	0	0	0	0	0	0	0	0	0	0	0	0	1	1	1	1	1	1	1	1
	Cyan	0	0	0	0	0	0	0	0	1	1	1	1	1	1	1	1	1	1	1	1	1	1	1	1
	Magenta	1	1	1	1	1	1	1	1	0	0	0	0	0	0	0	0	1	1	1	1	1	1	1	1
	Yellow	1	1	1	1	1	1	1	1	1	1	1	1	1	1	1	1	0	0	0	0	0	0	0	0
	White	1	1	1	1	1	1	1	1	1	1	1	1	1	1	1	1	1	1	1	1	1	1	1	1
Gray Scale Of Red	Red(0) / Dark	0	0	0	0	0	0	0	0	0	0	0	0	0	0	0	0	0	0	0	0	0	0	0	
	Red(1)	0	0	0	0	0	0	0	1	0	0	0	0	0	0	0	0	0	0	0	0	0	0	0	
	Red(2)	0	0	0	0	0	0	1	0	0	0	0	0	0	0	0	0	0	0	0	0	0	0	0	
	:	:	:	:	:	:	:	:	:	:	:	:	:	:	:	:	:	:	:	:	:	:	:	:	
	:	:	:	:	:	:	:	:	:	:	:	:	:	:	:	:	:	:	:	:	:	:	:	:	
	:	:	:	:	:	:	:	:	:	:	:	:	:	:	:	:	:	:	:	:	:	:	:	:	
	Red(253)	1	1	1	1	1	1	0	1	0	0	0	0	0	0	0	0	0	0	0	0	0	0	0	
	Red(254)	1	1	1	1	1	1	1	0	0	0	0	0	0	0	0	0	0	0	0	0	0	0	0	
Red(255)	1	1	1	1	1	1	1	1	0	0	0	0	0	0	0	0	0	0	0	0	0	0	0		
Gray Scale Of Green	Green(0) / Dark	0	0	0	0	0	0	0	0	0	0	0	0	0	0	0	0	0	0	0	0	0	0	0	
	Green(1)	0	0	0	0	0	0	0	0	0	0	0	0	0	0	1	0	0	0	0	0	0	0	0	
	Green(2)	0	0	0	0	0	0	0	0	0	0	0	0	0	1	0	0	0	0	0	0	0	0	0	
	:	:	:	:	:	:	:	:	:	:	:	:	:	:	:	:	:	:	:	:	:	:	:	:	
	:	:	:	:	:	:	:	:	:	:	:	:	:	:	:	:	:	:	:	:	:	:	:	:	
	:	:	:	:	:	:	:	:	:	:	:	:	:	:	:	:	:	:	:	:	:	:	:	:	
	Green(253)	0	0	0	0	0	0	0	1	1	1	1	1	1	0	1	0	0	0	0	0	0	0	0	
	Green(254)	0	0	0	0	0	0	0	1	1	1	1	1	1	1	0	0	0	0	0	0	0	0	0	
Green(255)	0	0	0	0	0	0	0	1	1	1	1	1	1	1	1	0	0	0	0	0	0	0	0		
Gray Scale Of Blue	Blue(0) / Dark	0	0	0	0	0	0	0	0	0	0	0	0	0	0	0	0	0	0	0	0	0	0	0	
	Blue(1)	0	0	0	0	0	0	0	0	0	0	0	0	0	0	0	0	0	0	0	0	0	0	1	
	Blue(2)	0	0	0	0	0	0	0	0	0	0	0	0	0	0	0	0	0	0	0	0	0	1	0	
	:	:	:	:	:	:	:	:	:	:	:	:	:	:	:	:	:	:	:	:	:	:	:	:	
	:	:	:	:	:	:	:	:	:	:	:	:	:	:	:	:	:	:	:	:	:	:	:	:	
	:	:	:	:	:	:	:	:	:	:	:	:	:	:	:	:	:	:	:	:	:	:	:	:	
	Blue(253)	0	0	0	0	0	0	0	0	0	0	0	0	0	0	1	1	1	1	1	1	1	0	1	
	Blue(254)	0	0	0	0	0	0	0	0	0	0	0	0	0	0	1	1	1	1	1	1	1	1	0	
Blue(255)	0	0	0	0	0	0	0	0	0	0	0	0	0	0	1	1	1	1	1	1	1	1	1		

Note (1) 0: Low Level Voltage, 1: High Level Voltage

## 6. INTERFACE TIMING

### 6.1 INPUT SIGNAL TIMING SPECIFICATIONS

The input signal timing specifications are shown as the following table and timing diagram.

Signal	Item	Symbol	Min.	Typ.	Max.	Unit	Note
LVDS Clock	Frequency	Fc	60.0	76	96	MHz	-
	Period	Tc	-	13.0	-	ns	-
	High Time	Tch	-	4/7	-	Tc	-
	Low Time	Tcl	-	3/7	-	Tc	-
LVDS Data	Setup Time	Tlvs	600	-	-	ps	-
	Hold Time	Tlvh	600	-	-	ps	-
Vertical Active Display Term	Frame Rate	Fr	50	60	75	Hz	Tv=Tvd+Tvb
	Total	Tv	800	806	815	Th	-
	Display	Tvd	768	768	768	Th	-
	Blank	Tvb	Tv-Tvd	38	Tv-Tvd	Th	-
Horizontal Active Display Term	Total	Th	1500	1560	1570	Tc	Th=Thd+Thb
	Display	Thd	1366	1366	1366	Tc	-
	Blank	Thb	Th-Thd	194	Th-Thd	Tc	-

Note: Because this module is operated by DE only mode, Hsync and Vsync input signals should be set to low logic level or ground. Otherwise, this module would operate abnormally.

#### INPUT SIGNAL TIMING DIAGRAM

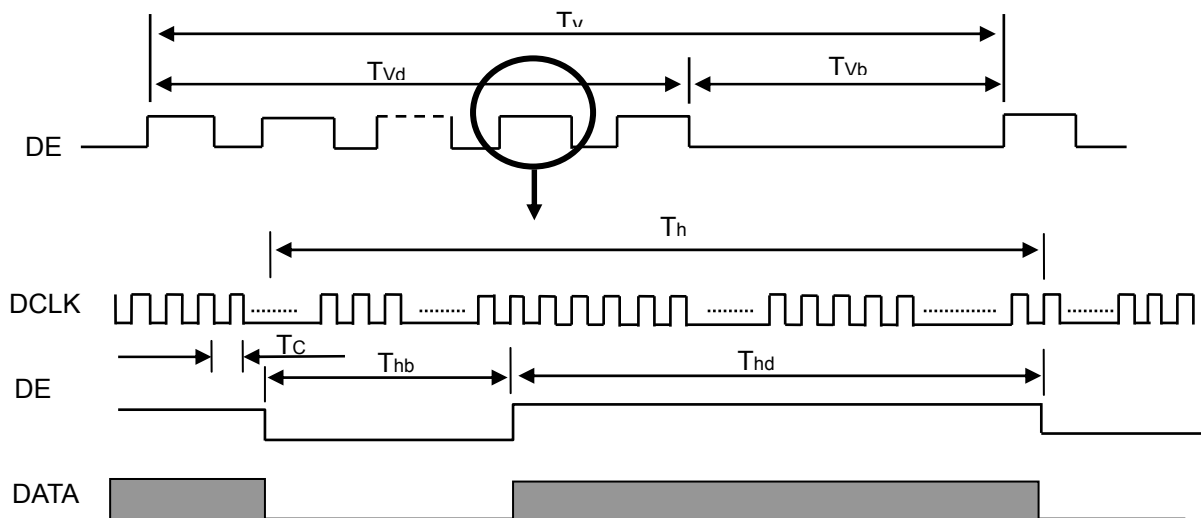

## 6.2 POWER ON/OFF SEQUENCE

To prevent a latch-up or DC operation of LCD module, the power on/off sequence should be as the diagram below.

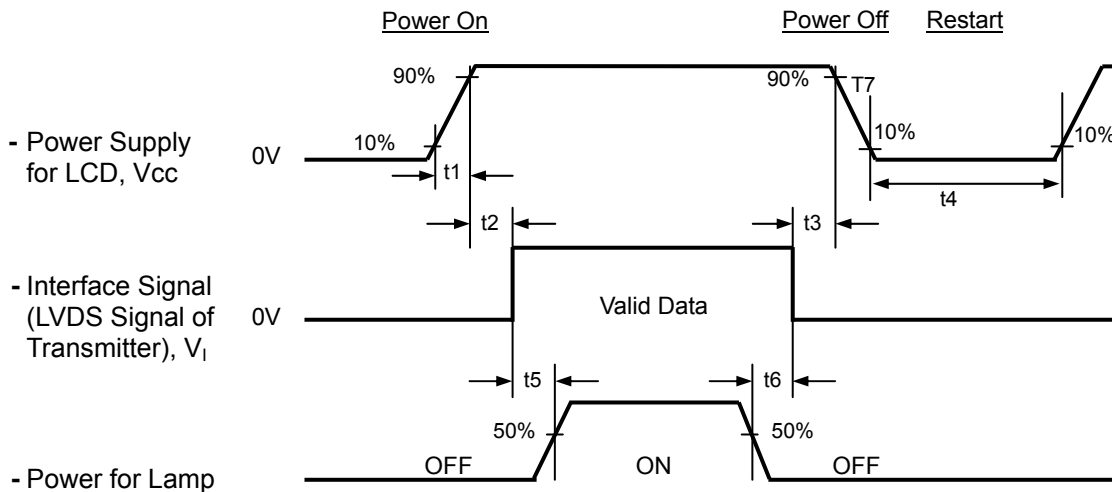

### Timing Specifications:

- $0.5 < t1 \leq 5 \text{ msec}$
- $0 < t2 \leq 50 \text{ msec}$
- $0 < t3 \leq 50 \text{ msec}$
- $t4 \geq 500 \text{ msec}$
- $t5 \geq 450 \text{ msec}$
- $t6 \geq 90 \text{ msec}$
- $5 \leq t7 \leq 100 \text{ msec}$

### Note.

- (1) The supply voltage of the external system for the module input should be the same as the definition of Vcc.
- (2) Apply the lamp voltage within the LCD operation range. When the backlight turns on before the LCD operation of the LCD turns off, the display may momentarily become abnormal screen.
- (3) In case of VCC = off level, please keep the level of input signals on the low or keep a high impedance.
- (4) T4 should be measured after the module has been fully discharged between power off and on period.
- (5) Interface signal shall not be kept at high impedance when the power is on.
- (6) CMO won't take any responsibility for the products which are damaged by the customers not following the Power Sequence.
- (7) There might be slight electronic noise when LCD is turned off (even backlight unit is also off). To avoid this symptom, we suggest "Vcc falling timing" to follow "t7 spec".

## 7. OPTICAL CHARACTERISTICS

### 7.1 TEST CONDITIONS

Item	Symbol	Value	Unit
Ambient Temperature	Ta	25±2	°C
Ambient Humidity	Ha	50±10	%RH
Supply Voltage	V <sub>CC</sub>	5.0	V
Input Signal	According to typical value in "3. ELECTRICAL CHARACTERISTICS"		
LED Light Bar Input Voltage	V <sub>LED</sub>	36.3	V <sub>DC</sub>
LED Light Bar Input Current	I <sub>LED</sub>	20	mA <sub>DC</sub>
Duty	D	100	%
Converter	Sumida		

### 7.2 OPTICAL SPECIFICATIONS

The relative measurement methods of optical characteristics are shown in 7.2. The following items should be measured under the test conditions described in 7.1 and stable environment shown in Note (5).

Item	Symbol	Condition	Min.	Typ.	Max.	Unit	Note		
Color Chromaticity (CIE 1931)	Red	$\theta_x=0^\circ, \theta_y=0^\circ$ CS-1000T	Typ - 0.03	Typ + 0.03	-	-	(1), (5)		
								Rx	0.636
	Ry							0.345	
	Green							Gx	0.332
								Gy	0.609
	Blue							Bx	0.156
								By	0.061
	White							Wx	0.313
Wy		0.329							
Center Luminance of White (Center of Screen)	L <sub>C</sub>		200	250	-	cd/m <sup>2</sup>	(4), (5)		
Contrast Ratio	CR		700	1000	-	-	(2), (5)		
Response Time	T <sub>R</sub>	$\theta_x=0^\circ, \theta_y=0^\circ$	-	1.3	3.2	ms	(3)		
	T <sub>F</sub>							3.7	6.8
White Variation	δW	$\theta_x=0^\circ, \theta_y=0^\circ$ USB2000	-	1.3	1.5	-	(5), (6)		
Viewing Angle	Horizontal	CR ≥ 10 USB2000	75	85	-	Deg.	(1), (5)		
								θ <sub>x+</sub>	
	θ <sub>x-</sub>								
	Vertical							θ <sub>y+</sub>	70
		θ <sub>y-</sub>	70	80	-				
	Horizontal	CR ≥ 5 USB2000	80	89	-	Deg.			
								θ <sub>x+</sub>	
								θ <sub>x-</sub>	
Vertical							θ <sub>y+</sub>	75	85
	θ <sub>y-</sub>	75	85	-					

Note (1) Definition of Viewing Angle ( $\theta_x$ ,  $\theta_y$ ):

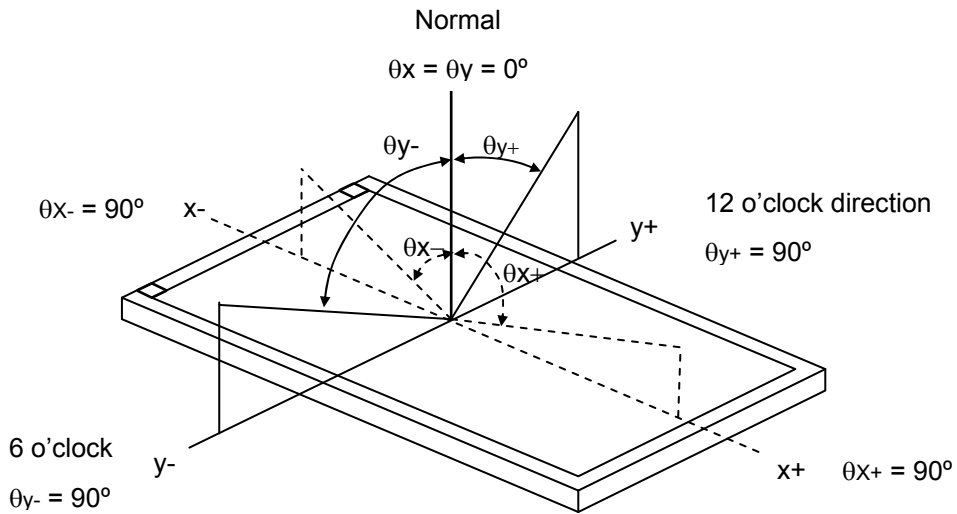

Note (2) Definition of Contrast Ratio (CR):

The contrast ratio can be calculated by the following expression.

$$\text{Contrast Ratio (CR)} = L_{255} / L_0$$

L255: Luminance of gray level 255

L 0: Luminance of gray level 0

**CR = CR (5)**

CR (X) is corresponding to the Contrast Ratio of the point X at Figure in Note (6).

Note (3) Definition of Response Time ( $T_R$ ,  $T_F$ ):

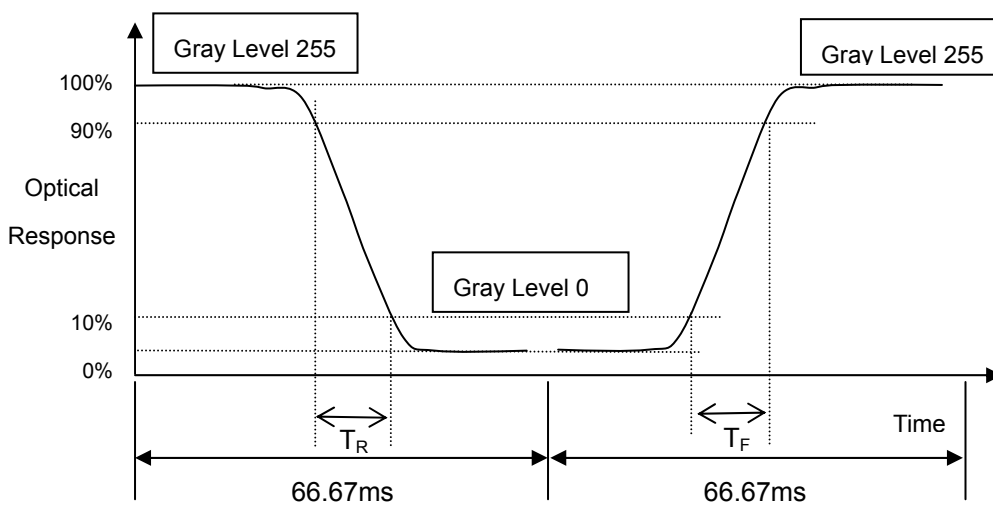



Note (4) Definition of Luminance of White ( $L_c$ ):

Measure the luminance of gray level 255 at center point

$$L_c = L(5)$$

$L(x)$  is corresponding to the luminance of the point X at Figure in Note (6).

Note (5) Measurement Setup:

The LCD module should be stabilized at given temperature for 20 minutes to avoid abrupt temperature change during measuring. In order to stabilize the luminance, the measurement should be executed after lighting Backlight for 20 minutes in a windless room.

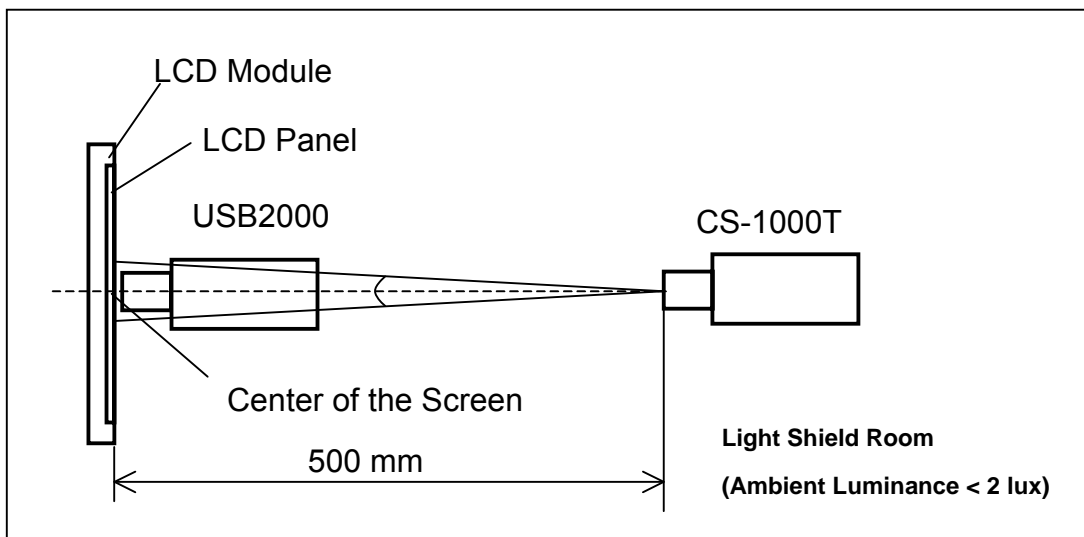

Note (6) Definition of White Variation ( $\delta W$ ):

Measure the luminance of gray level 255 at 9 points

$$\delta W = \text{Maximum} [L(1), L(2) \dots L(4), L(9)] / \text{Minimum} [L(1), L(2) \dots L(4), L(9)]$$

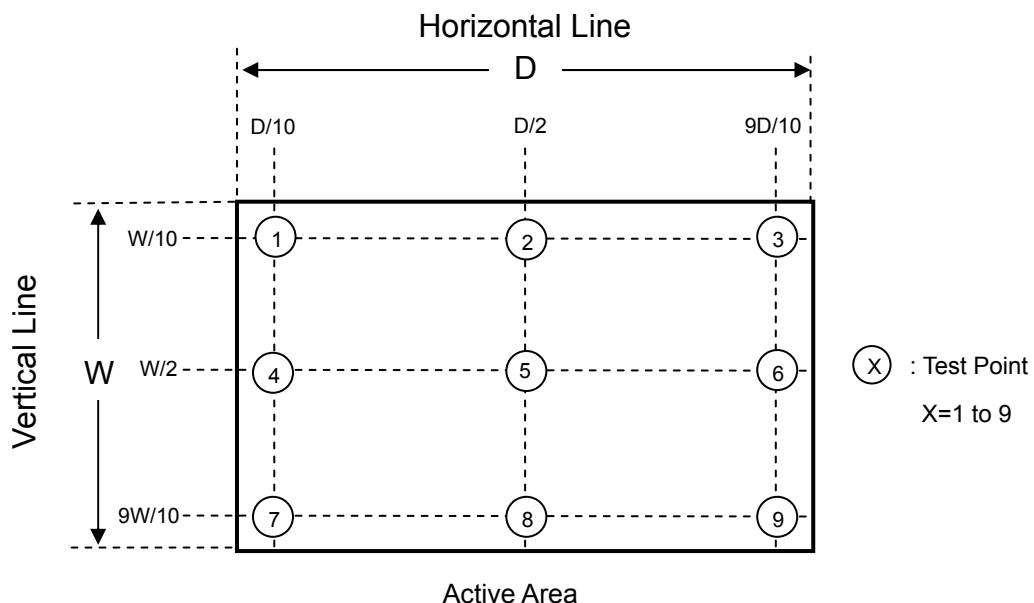

## 8. PACKAGING

### 8.1 PACKING SPECIFICATIONS

- (1) 14 LCD modules / 1 Box
- (2) Box dimensions: 525(L) X 284 (W) X 360 (H) mm
- (3) Weight: 20.45Kg (14 modules per box)

### 8.2 PACKING METHOD

- (1) Carton Packing should have no failure in the following reliability test items.

Test Item	Test Conditions	Note
Vibration	ISTA STANDARD Random, Frequency Range: 1 – 200 Hz Top & Bottom: 30 minutes (+Z), 10 min (-Z), Right & Left: 10 minutes (X) Back & Forth 10 minutes (Y)	Non Operation
Dropping Test	1 Angle, 3 Edge, 6 Face, 45.7cm	Non Operation

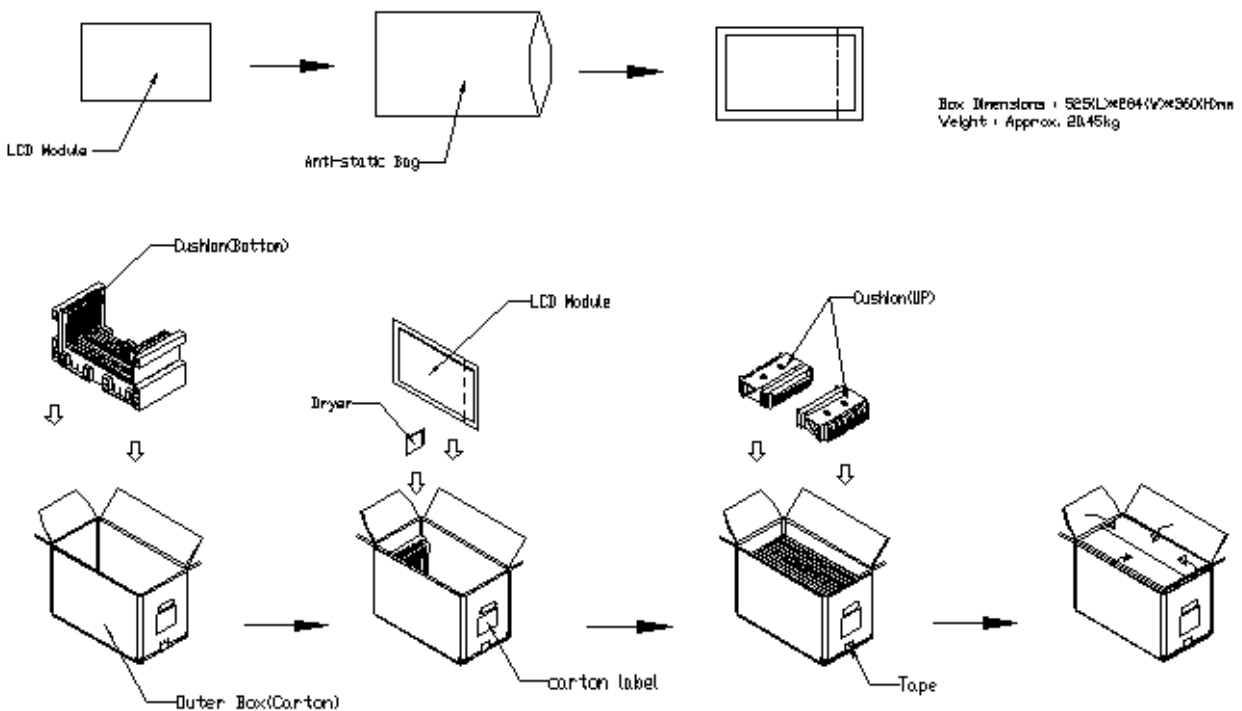

**Figure. 8-1 Packing method**

For ocean shipping

Sea / Land Transportation (40ft HQ Container)

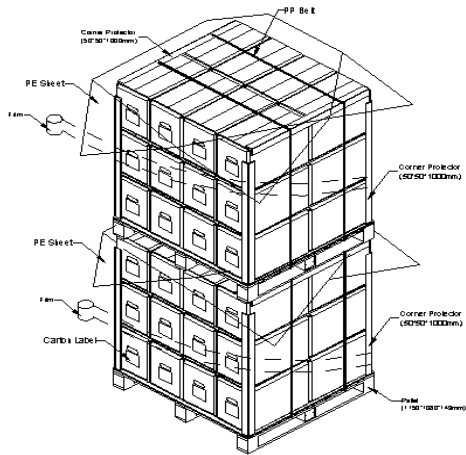

Sea / Land Transportation (40ft Container)

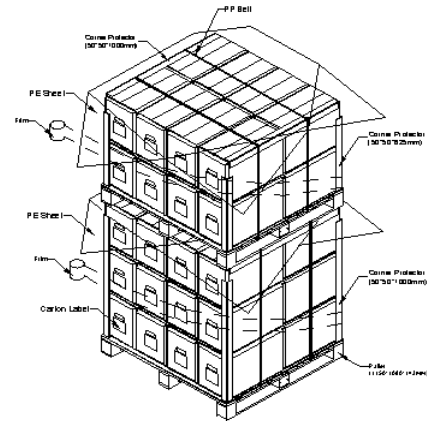

**Figure. 8-2 Packing method**

For air transport

Air Transportation

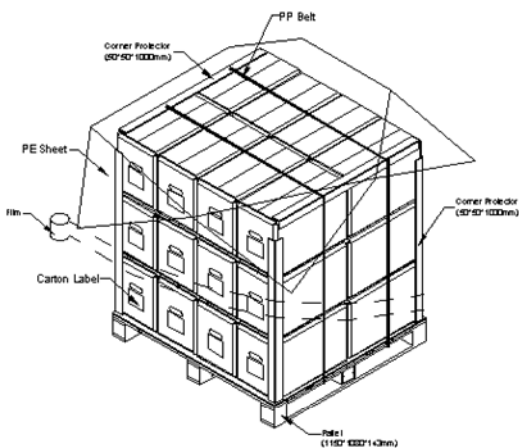

**Figure. 8-3 Packing method**

## 9. DEFINITION OF LABELS

### 9.1 CMO MODULE LABEL

The barcode nameplate is pasted on each module as illustration, and its definitions are as following explanation.



- (a) Model Name: M185B3-L01
- (b) Revision: Rev. XX, for example: A0, A1... B1, B2... or C1, C2...etc.
- (c) CMO barcode definition:

Serial ID: XX-XX-X-XX-YMD-L-NNNN

Code	Meaning	Description
XX	CMO internal use	-
XX	Revision	Cover all the change
X	CMO internal use	-
XX	CMO internal use	-
YMD	Year, month, day	Year: 2001=1, 2002=2, 2003=3, 2004=4... Month: 1~12=1, 2, 3, ~, 9, A, B, C Day: 1~31=1, 2, 3, ~, 9, A, B, C, ~, W, X, Y, exclude I, O, and U.
L	Product line #	Line 1=1, Line 2=2, Line 3=3, ...
NNNN	Serial number	Manufacturing sequence of product

- (d) Customer's barcode definition:

Serial ID: CM-18B31-X-X-X-XX-L-XX-L-YMD-NNNN

Code	Meaning	Description
CM	Supplier code	CMO=CM
18B31	Model number	M185B3-L01 = 18B31
X	Revision code	Non ZBD: 1,2,~,8,9 / ZBD: A~Z
X	Source driver IC code	Century=1, CLL=2, Demos=3, Epson=4, Fujitsu=5, Himax=6, Hitachi=7, Hynix=8, LDI=9, Matsushita=A, NEC=B, Novatec=C, OKI=D, Philips=E, Renasas=F, Samsung=G, Sanyo=H, Sharp=I, TI=J, Topro=K, Toshiba=L, Windbond=M
X	Gate driver IC code	
XX	Cell location	Tainan Taiwan=TN
L	Cell line #	1,2,~,9,A,B,~,Y,Z
XX	Module location	Tainan Taiwan=TN ; Ningbo China=NP
L	Module line #	1,2,~,9,A,B,~,Y,Z
YMD	Year, month, day	Year: 2001=1, 2002=2, 2003=3, 2004=4... Month: 1~12=1, 2, 3, ~, 9, A, B, C Day: 1~31=1, 2, 3, ~, 9, A, B, C, ~, T, U, V
NNNN	Serial number	By LCD supplier

- (e) UL Factory ID:

Region	Factory ID
TWCMO	GEMN
NBCMO	LEOO
NBCME	CANO
NHCMO	CAPG

## 10. RELIABILITY TEST

Environment test conditions are listed as following table.

Items	Required Condition	Note
Temperature Humidity Bias (THB)	Ta= 50°C , 80%RH, 240hours	
High Temperature Operation (HTO)	Ta= 50°C , 50%RH , 240hours	
Low Temperature Operation (LTO)	Ta= 0°C , 240hours	
High Temperature Storage (HTS)	Ta= 60°C , 240hours	
Low Temperature Storage (LTS)	Ta= -20°C , 240hours	
Vibration Test (Non-operation)	Acceleration: 1.5 Grms Wave: Half-sine Frequency: 10 - 300 Hz Sweep: 30 Minutes each Axis (X, Y, Z)	
Shock Test (Non-operation)	Acceleration: 50 G Wave: Half-sine Active Time: 11 ms Direction : ± X, ± Y, ± Z.(one time for each Axis)	
Thermal Shock Test (TST)	-20°C/30min , 60°C / 30min , 100 cycles	
On/Off Test	25°C ,On/10sec , Off /10sec , 30,000 cycles	
ESD (Electro Static Discharge)	Contact Discharge: ± 8KV, 150pF(330Ω)	
	Air Discharge: ± 15KV, 150pF(330Ω)	
Altitude Test	Operation:10,000 ft / 24hours Non-Operation:30,000 ft / 24hours	

## 11. PRECAUTIONS

### 11.1 ASSEMBLY AND HANDLING PRECAUTIONS

- (1) Do not apply rough force such as bending or twisting to the module during assembly.
- (2) To assemble or install module into user's system can be only in clean working areas. The dust and oil may cause electrical short or worsen the polarizer.
- (3) It's not permitted to have pressure or impulse on the module because the LCD panel and Backlight will be damaged.
- (4) Always follow the correct power sequence when LCD module is connecting and operating. This can prevent damage to the CMOS LSI chips during latch-up.
- (5) Do not pull the I/F connector in or out while the module is operating.
- (6) Do not disassemble the module.
- (7) Use a soft dry cloth without chemicals for cleaning, because the surface of polarizer is very soft and easily scratched.
- (8) It is dangerous that moisture come into or contacted the LCD module, because moisture may damage LCD module when it is operating.
- (9) High temperature or humidity may reduce the performance of module. Please store LCD module within the specified storage conditions.
- (10) When ambient temperature is lower than 10°C may reduce the display quality. For example, the response time will become slowly, and the starting voltage of CCFL will be higher than room temperature.

### 11.2 SAFETY PRECAUTIONS

- (1) The startup voltage of Backlight is approximately 1000 Volts. It may cause electrical shock while assembling with inverter. Do not disassemble the module or insert anything into the Backlight unit.
- (2) If the liquid crystal material leaks from the panel, it should be kept away from the eyes or mouth. In case of contact with hands, skin or clothes, it has to be washed away thoroughly with soap.
- (3) After the module's end of life, it is not harmful in case of normal operation and storage.

### 11.3 SAFETY STANDARDS

The LCD module should be certified with safety regulations as follows:

- (1) UL60950-1 or updated standard.
- (2) IEC60950-1 or updated standard.

### 11.4. Storage

- (1) Do not leave the module in high temperature, and high humidity for a long time.  
It is highly recommended to store the module with temperature from 0°C to 35°C  
And relative humidity of less than 70%

- (2) Do not store the TFT – LCD module in direct sunlight
- (3) The module should be stored in dark place. It is prohibited to apply sunlight or fluorescent light in storing

#### 11.5. Operation condition guide

- (1) The LCD product should be operated under normal condition.

Normal condition is defined as below :

Temperature :  $20\pm 15^{\circ}\text{C}$

Humidity:  $65\pm 20\%$

Display pattern : continually changing pattern(Not stationary)

- (2) If the product will be used in extreme conditions such as high temperature , high humidity , high altitude , display pattern or operation time etc...It is strongly recommended to contact CMO for application engineering advice . Otherwise , Its reliability and function may not be guaranteed.

#### 11.6 OTHER

When fixed patterns are displayed for a long time, remnant image is likely to occur.

### 12. MECHANICAL CHARACTERISTICS

[Refer to the next 2 pages]

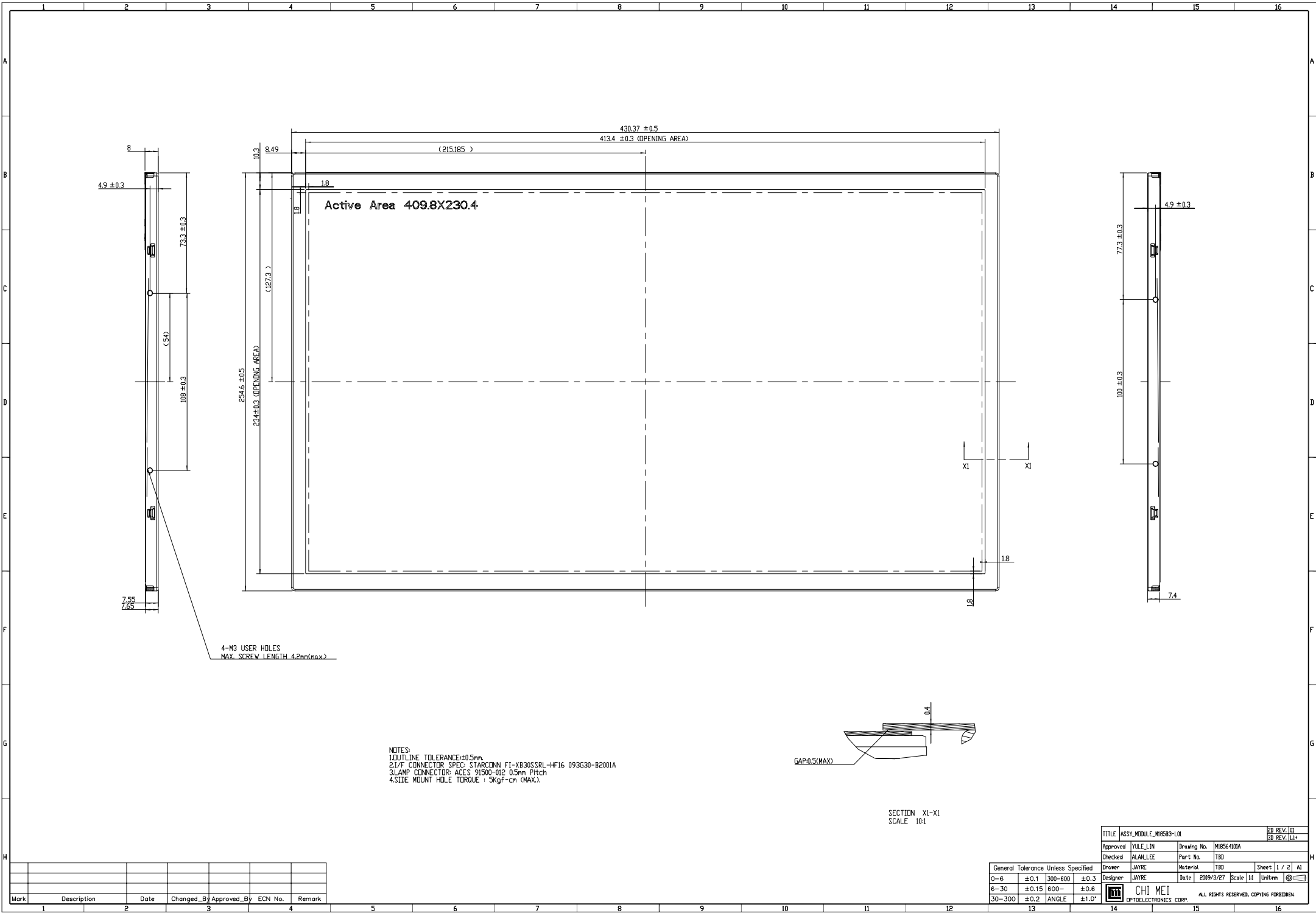

Active Area 409.8X230.4

4-M3 USER HOLES  
MAX. SCREW LENGTH 4.2mm(max.)

NOTES:  
1. OUTLINE TOLERANCE: ±0.5mm.  
2. 1/4" CONNECTOR SPEC. STARCONN FI-XB30SRL-HF16 093G30-B2001A  
3. LAMP CONNECTOR: ACES 91500-012 0.5mm Pitch  
4. SIDE MOUNT HOLE TORQUE : 5KgF-cm (MAX.)

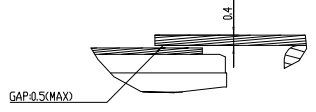

SECTION X1-X1  
SCALE 10:1

Mark	Description	Date	Changed_By	Approved_By	ECN No.	Remark
1						
2						
3						
4						

General Tolerance Unless Specified		0-6 ±0.1		300-600 ±0.3		6-30 ±0.15		600- ±0.6		30-300 ±0.2		ANGLE ±1.0°	
TITLE ASSY_MODULE_M18563-L01		2D REV. 01		3D REV. 111		Approved YULE LIN		Drawing No. M18564101A		Checked ALAN LEE		Part No. TBD	
Designer JAYRE		Material TBD		Date 2009/3/27		Scale 1:1		Unit:mm		Sheet 1 / 2		A1	
CHI MEI OPTOELECTRONICS CORP.		ALL RIGHTS RESERVED. COPYING FORBIDDEN											



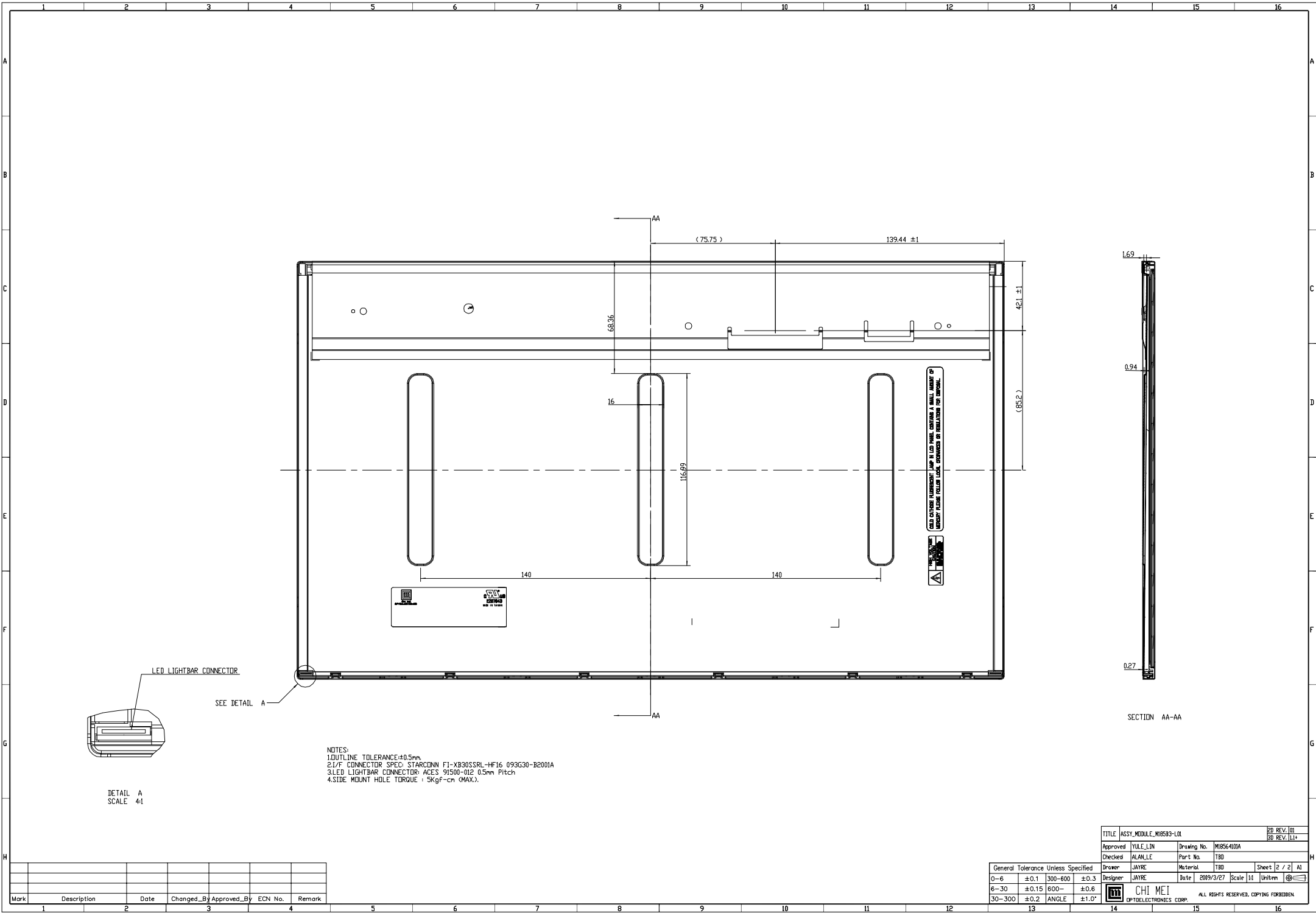

LED LIGHTBAR CONNECTOR

SEE DETAIL A

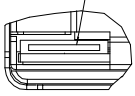

DETAIL A  
SCALE 4:1

- NOTES:  
 1. OUTLINE TOLERANCE: ±0.5mm  
 2. I/PF CONNECTOR SPEC: STARCINN F1-XB30SSRL-HF16 093G30-B2001A  
 3. LED LIGHTBAR CONNECTOR: ACES 91500-012 0.5mm Pitch  
 4. SIDE MOUNT HOLE TORQUE : 5kgf-cm (MAX).

WELD CRACKS PLACEMENT: JAP IN LUG SHALL CONTAIN A SMALL AMOUNT OF MERCURY PASTE TO FILL CRACKS TO PREVENT CRACKS FROM PROPAGATING.

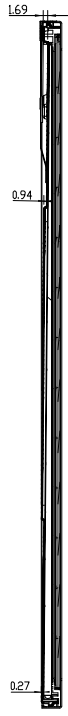

SECTION AA-AA

Mark	Description	Date	Changed_By	Approved_By	ECN No.	Remark
1						
2						
3						
4						

General Tolerance Unless Specified				DRAWER		DATE		SCALE		SHEET	
0-6	±0.1	300-600	±0.3	JAYRE	TBD	2009/3/27	1:1	2 / 2	A1		
6-30	±0.15	600-	±0.6	JAYRE	TBD						
30-300	±0.2	ANGLE	±1.0°	CHI MEI OPTOELECTRONICS CORP.		ALL RIGHTS RESERVED. COPYING FORBIDDEN					